

## BLDC SPEED CONTROL UNIT

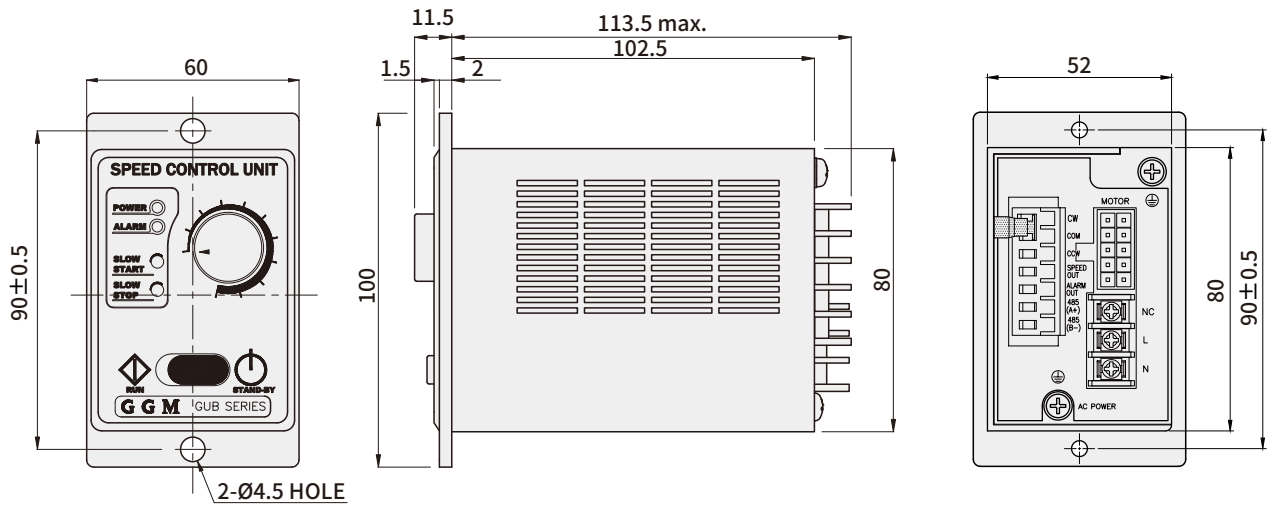

GUB-C-30	GUB-U-30	B Series motor applied product
GUB-C-60	GUB-U-60	
GUB-C-90	GUB-U-90	
GUB-C-150		

### Product appearance and characteristics



- Easy connection, easy manipulation  
Motor and wire get easily connected by just connecting speed control unit connector. Volume in front face can simply set up motor rotation speed.
- External control function  
On/off, change of rotation direction and instant stop can be controlled through outside signal (sequencer or relay signal). Also, separate volume and direct power can be accessed from outside and speed setting is possible by external signal.
- Slow start, slow down functions  
Motor is maneuvered at the set acceleration time and stopped at the set deceleration time. This acceleration and deceleration times can be controlled within 0.5~10 seconds.

#### Extension cable

Buy extension cable to additionally extend between motor and control (optional)

#### -DIMENSION

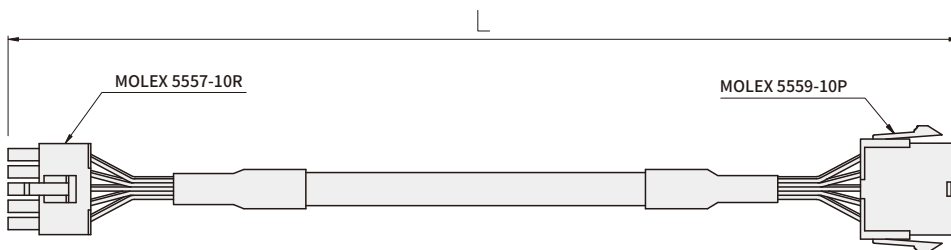

MODEL	L (extension cable length)
KBEW-1	1m
KBEW-2	2m
KBEW-3	3m
KBEW-5	5m
KBEW-10	10m

## → Name and functions of each part

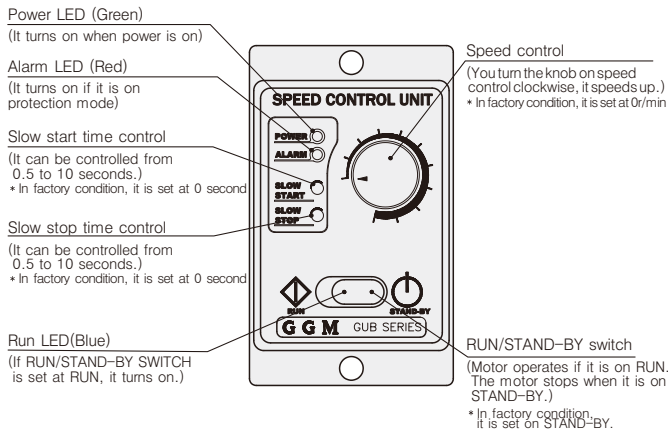

### Input/output signal connection socket

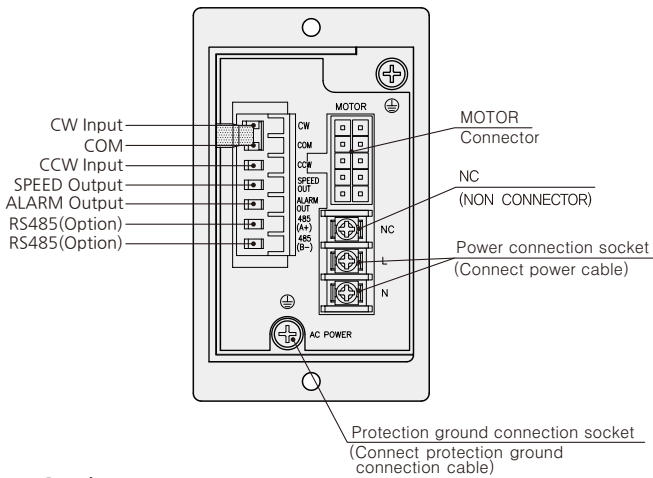

### ※ Caution

- RUN/STAND-BY SWITCH is not power switch.
- When you are stopping motor for a long time, turn the control unit off.

### Access motor and control unit

#### ■ Access motor and control unit

Connect connector of motor cable to control unit. Push in until clicks. Do not manipulate extension cable(optional) when you are extending motor and control unit. Do not peel off cable cover or ground and touch shield wire.

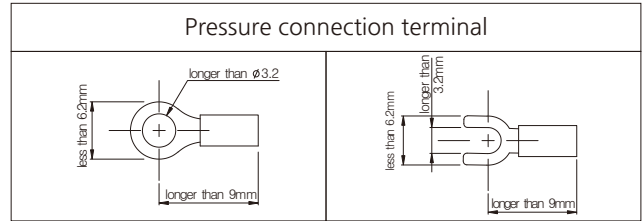
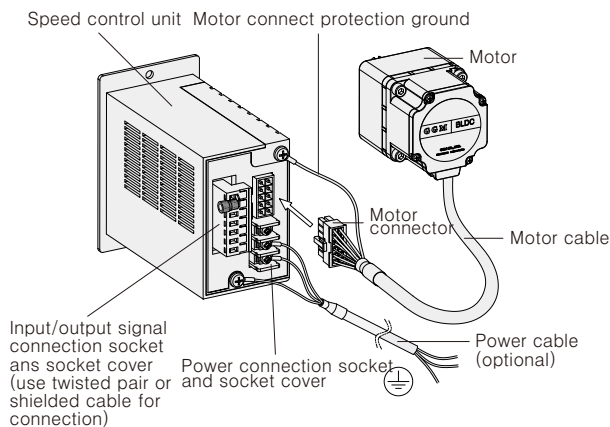

#### ■ Power access

Connect accessory power cable to the control unit contact socket. If you are not using accessory power cable, use a cable that is bigger than AWG22(0.34mm<sup>2</sup>). When connecting, use insulation attached round type crimp terminal.

#### ■ Ground

Use a cable bigger than AWG18(0.75mm<sup>2</sup>) for protection ground connection cable.

- Attach control unit to a vibration-resistant flat metal plate.
- When you are using mounting hole of control unit, tighten with M4 screws and nuts.
- When installing control unit, let one of the vents face downwards.
- Control unit should be installed more than 25mm away from the mounting box and other equipment in the mounting box horizontally and 50mm away from them vertically.

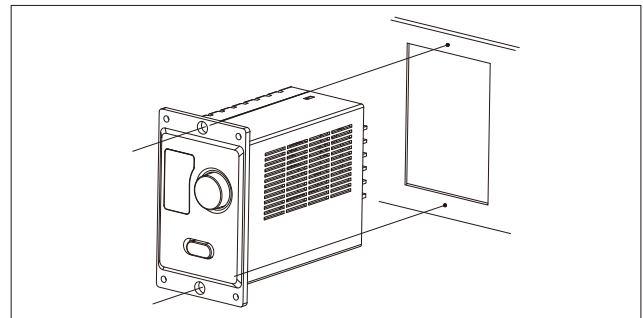

### Control unit panel manufacturing plan

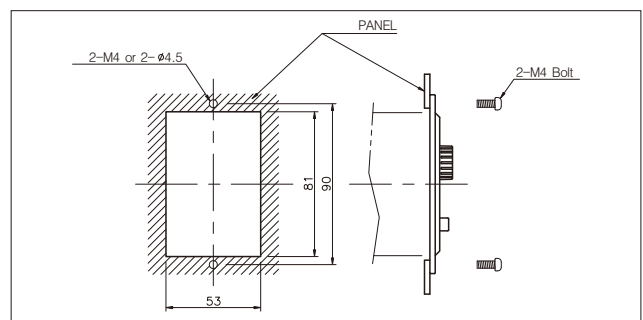

### ※ Caution

- Keep the torque of fixing screw less than 10kgf·cm. If it is fixed with more than 10kgf·cm torque, the control unit might break.

## Operation

- Rotation direction is when you look at it from output axis of motor. CW is clockwise and CCW is counterclockwise.

### When only operating with the main part

- If you turn RUN/STANDY-BY SWITCH to RUN, then the motor rotates. If you turn RUN/STANDY-BY SWITCH to STAND-BY, then the motor stop.

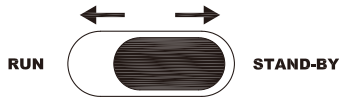

- The rotation direction is determined by the short bar connection status on the back of the control unit. connect accessory short bar between CW-COM and CCW-COM. Do not use short bar for other purposes.

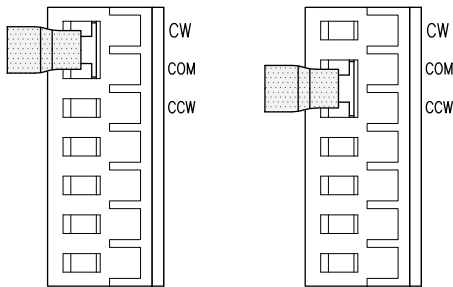

### Controller of transistor output type

- Use small size connection TYPE relay to open and close DC 12V, 5mA
- CW(clockwise)operation :  
If it is set at CW and on, then the motor rotates clockwise, If CW input is off, then the motor stops.
- CCW(counterclockwise)operation :  
If it is set at CCW and on, then the motor rotates counterclockwise. If CCW input is off, then the motor stops.
- If CW and CCW are put in at the same time and on, then the motor stops instantly. At then moment, instant reverse operation is not possible.
- Give more than 20msec of time interval between CW signal and CCW signal inputs.
- Do not use SSR(SOLID STATE RELAY) on power ON/OFF Motor control unit may break.
- If you are using controller with clamp diode installed, be careful of power on/off order.  
- Power ON : CONTROLLER ON → CONTROL UNIT ON  
- Power OFF : CONTROL UNIT OFF → CONTROLLER OFF

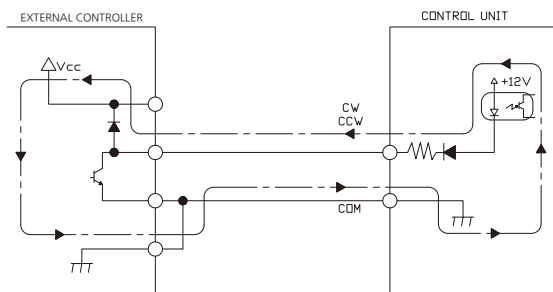

When you connect like the diagram above, if you turn the control unit power on first or if you turn the controller off while control unit is on, then the electricity flows and motor rotates.

There is a chance that motor might rotate due to power capacity difference even if you turn the power on and off at the same time. Controller should be turned on first and control unit is off first in case of power.

## Signal output circuit

### Output circuit

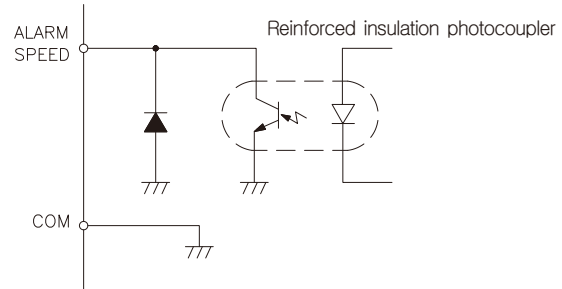

### Example of output circuit connection

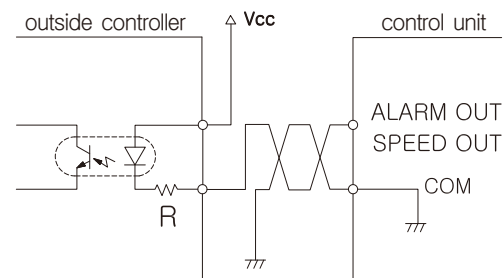

- Signal output is open collector output.
- Use power of less than DC26.4V to connect restricted resistance with less than 10mA.

## SPEED OUT

If synchronizes with motor operation that it creates 30 pulses signal per 1 rotation of motor output axis. Measure speed out frequency to calculate motor rotation speed.

- Motor Rotation speed [RPM] =  $\frac{\text{SPEED OUT Frequency(Hz)}}{15} \times 60$
- SPEED OUT Frequency(Hz) =  $\frac{1}{T}$
- SPEED OUT TERMINAL are on the controller back.

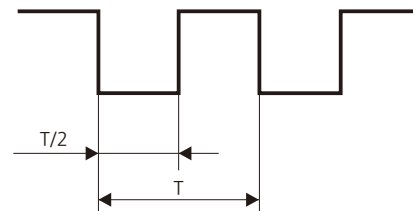

■ Motor speed pulse output

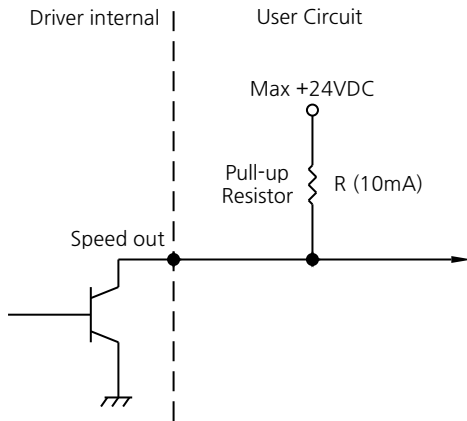

※ I/O #12 outputs signal pulse while motor rotation.  
(outputs 15 pulses of signal per 1 motor rotation)

## ALARM OUTPUT

In the following case, control unit protection function gets turned on and alarm out gets also turned on (L-LEVEL). Then, the motor stops. In this case, it is shown with LED light on or off. Check the protection details.

Item	LED sign	Note
Hall sensor alarm	Flickering 1 times at 6 seconds intervals (Red)	Motor stop
Over load alarm	Flickering 3 times at 6 seconds intervals (Red)	
Over heat alarm	Flickering 5 times at 6 seconds intervals (Red)	
Over voltage alarm	Flickering 6 times at 6 seconds intervals (Red)	
Over current alarm	Flickering 8 times at 6 seconds intervals (Red)	
Normality	Green light on ( Power )	

※ When you are providing power, if the LED light turns on instantaneously, that is not a sign of malfunctioning.

### LED flickering

■ If torque that is greater than the rating is applied to the motor for more than 5 seconds or if the motor rotation direction changes quickly or turns on/off.

### LED on

- If there is a problem with motor feedback signal due to motor cable disconnection and connector connection problem
- If load is being carried downwards or too much load is operated on

When you access by following the direction above, alarm output will be off when control unit is (H-LEVEL) and on when control unit is(L-LEVEL), stop the motor and turn off the control unit.

If there is no problem with motor cable, check other use conditions (load torque, operation pattern and power voltage) Remove the reasons of protection mode and reapply power to reset alarm output

- When you extend input/output signal cable, do it for less than 2m. Try to make it as short as possible to minimize noise.
- input/output signal cable should be separated from power cable and motor cable.

## SLOW START

Motor response speed can be set between 0.5~10 seconds (at 2000rpm)

## SLOW STOP

If you are stopping motor from outside, you can set the motor stopping time at 0.5-10 seconds (at 2000rpm)

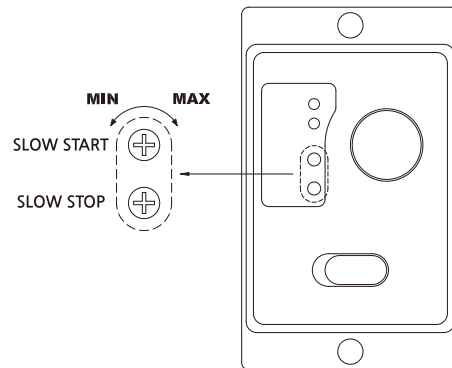

- If you turn it clockwise, the time gets longer.
- When you are changing the setting, use accurate cross screwdriver.
- In factory condition, it is set at the shortest time possible.