

Profile

- Small dimensions, high power density
- easy mounting and commissioning
- High flexibility, high protection category
- stainless steel 14 mm diam. hollow shaft, robust housing
- Brushless EC motor with a long service life
- solid absolute sensor, magnetic sensing technology
- integrated power and control electronics
- Integrated Industrial-Ethernet-Fieldbus
- Integrated positioning controller
- M12 component mounting technology

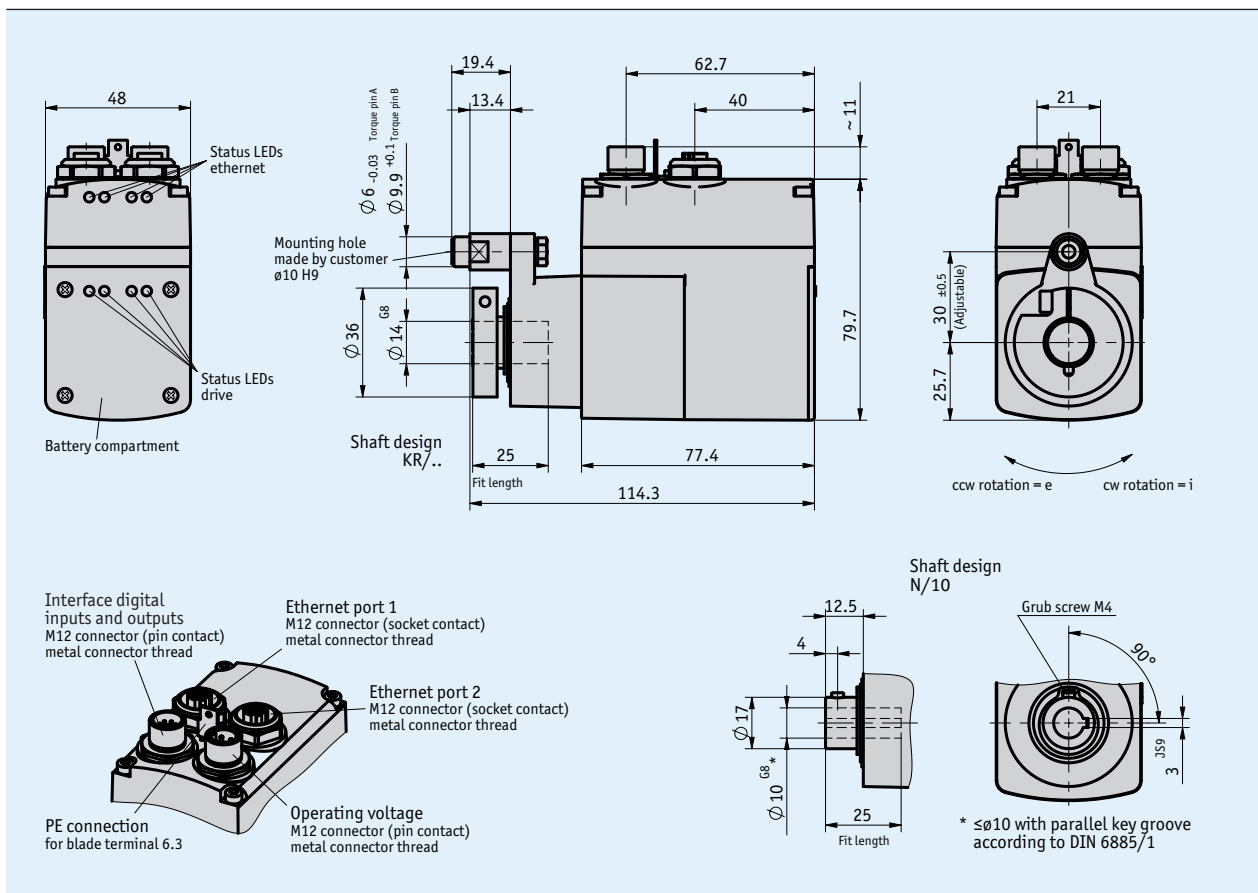

Mechanical data

Feature	Technical data	Additional information
Shaft	stainless steel	
Housing	glass-fiber reinforced plastic / zinc die-cast	
Clamping ring	stainless steel	
Torque pin	stainless steel	form A
	stainless steel	form B
Nominal torque/rated speed	5 Nm at 50 rpm ±10 %	i = 98
	3 Nm at 75 rpm ±10 %	i = 66
Operating mode	intermittent duty S3: 25% DC, 10 min.	EN 60034-1
Weight	~0.8 kg	

Electrical data

Feature	Technical data	Additional information
Operating voltage	24 V DC $\pm 10\%$	reverse polarity protected, output stage
	24 V DC $\pm 10\%$	reverse polarity protected, control
Current consumption	2.2 A $\pm 10\%$	at nominal torque/speed (output stage)
	<150 mA	starting current >150 mA (control)
Power input	≤ 58 W	output stage
	≤ 3.6 W	control
Battery	CR2477N, 3 V lithium, 950 mAh	
Battery service life	~5 year(s)	depending on ambient conditions
Digital inputs	17 ... 30 V DC	typically 10 mA
Status display	8 LEDs	
Keys	2 internal keys, internal DIP switch	
Switching outputs	24 V DC $\pm 10\%$	≤ 40 mA
Bus connection	EIP-EtherNet/IP	
	EPN-PROFINET	
	ECT-EtherCAT	
	EPL-POWERLINK	
Type of connection	2x M12 plug connectors (A-coded)	4-pole, 1x pin; 8-pole, 1x pin
	2x M12 plug connectors (D-coded)	4-pole, 2x socket
	grounding via flat connector 6.3 mm	

System data

Feature	Technical data	Additional information
Resolution	720 steps/revolution shaft	
Repeat accuracy	± 1 steps/revolution	
Travel range	± 1300 revolution(s)	i = 98
	± 1980 revolution(s)	i = 66

Ambient conditions

Feature	Technical data	Additional information
Ambient temperature	0 ... 45 °C	
Storage temperature	-20 ... 60 °C	
Relative humidity		condensation inadmissible
EMC	EN 61800-3, second environment	interference resistance / immission
	EN 61800-3, C2	emitted interference / emission
Protection category	IP54, IP65	EN 60529, only with mating connector
Shock resistance	500 m/s ² , 8 ms	EN 60068-2-27
Vibration resistance	<100 m/s ² , 5 ... 150 Hz	EN 60068-2-6

Pin assignment

■ EtherCAT, EtherNet/IP, POWERLINK, PROFINET

Signal	PIN
Tx+	1
Rx+	2
Tx-	3
Rx-	4

■ Operating voltage (output stage / control)

Signal	PIN
+UB (output stage)	1
+UB (control)	2
GND (output stage)*	3
GND (control)*	4

* internally connected with SGND

■ Digital inputs / outputs

Signal	PIN
Input 1	1
Input 2	2
Input 3	3
Input 4	4
Output 1	5
RXD	6
TXD	7
SGND*	8

* internally connected with GND of operating voltage

Performance curve

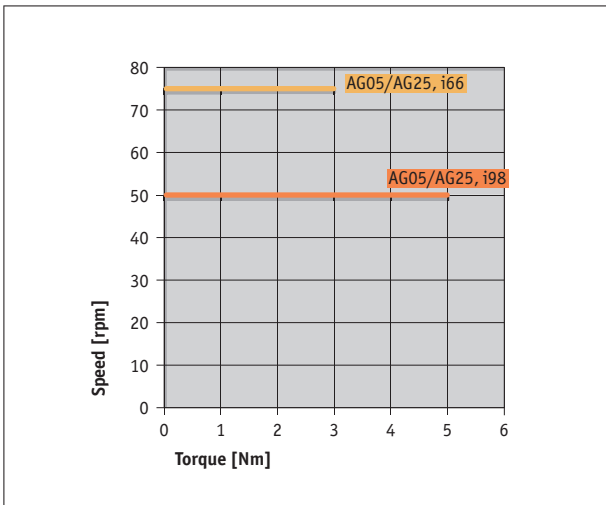

Order

Ordering table

Feature	Ordering data	Specification	Additional information
Gear ratio	66	i = 66	
	98	i = 98	
Protection category	IP54	IP54	
	IP65	IP65	
Shaft design/diameter	KR/14	clamping ring, ø14 mm	
	N/10	keyway, ø10 mm	
Torque pin	A	bolt, ø6 mm	
	B	bolt, ø10 mm	Aluminum
Interface/protocol	ECT	EtherCAT	
	EIP	EtherNet/IP	
	EPL	POWERLINK	
	EPN	PROFINET	

Order key

AG25 Fieldbus/IE - A - 50W - B - C - D - ABM - E - SW

Scope of delivery: AG25 Fieldbus/IE, Mounting instructions, Documentation on CD

Accessories:

- angular gear WG05
- Cable extension KV04S2
- Cable extension KV08S2
- Programming software ProTool DL
- Mating Connector Overview, overview
- Mating connector, operating voltage, 4-pole, socket
- Mating connector, operating voltage, 4-pole, angle socket
- Mating connector, digital inputs/outputs, 8-pole, socket
- Mating connector, digital inputs/outputs, 8-pole, angle socket
- Mating connector, port 1 + port 2, 4-pole, pin
- Mating connector, port 1 + port 2, 4-pole, angular pin

- www.siko-global.com
- www.siko-global.com
- www.siko-global.com
- www.siko-global.com
- www.siko-global.com
- Order key 83526
- Order key 83091
- Order key 83525
- Order key 87599
- Order key 87601
- Order key 87600